

# SRS1612 double-stage hermetic Compressor

[srmtecgroup.com/products/compressors/srs-1612/](http://srmtecgroup.com/products/compressors/srs-1612/)

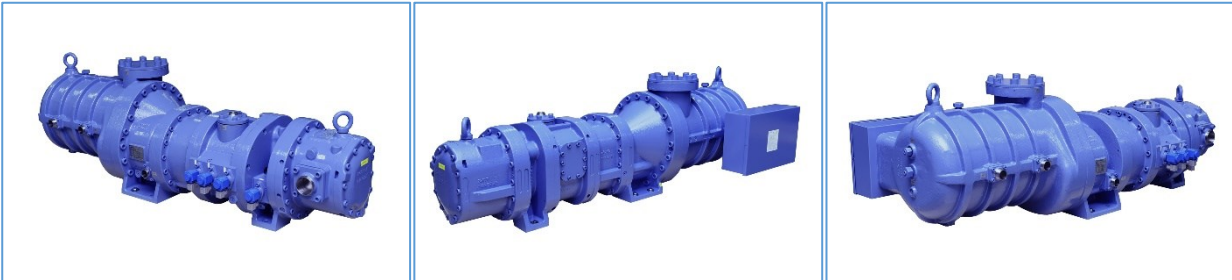

SRS1612 Series		
Model	SRS1612MS	SRS1612LS
Displacement @2960 rpm [m3/h]	544 / 215	652 / 215
Displacement @3600 rpm [m3/h]	661 / 261	792 / 261
Capacity Control	Step control: 25%, 50%, 75%, 100%; step-less	
Max. rpm	3600	
Vi Control	Fix	
Vi adjustment range	2.5/3.0/4.5	
Rotation, onto compressor shaft	counter-clockwise, looking at the compressor input shaft	
Non-return valve suction side	Lift check valve	
Suction inlet diameter [mm]	DN 125	DN 125
Discharge outlet diameter [mm]	DN 65	DN 65
Eco connection [mm]	DN 32	DN 32
Design pressure	28 bar	
Length [mm]	1932	1986
Width [mm]	819	819
Height [mm]	686	686
Weight [kg]	1139	1161

# SRS1612LS

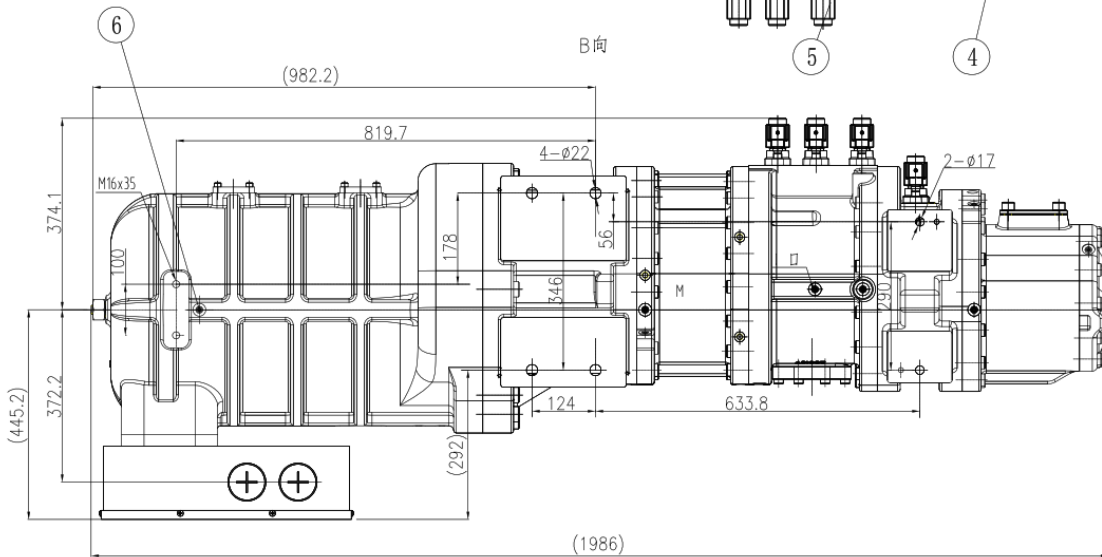
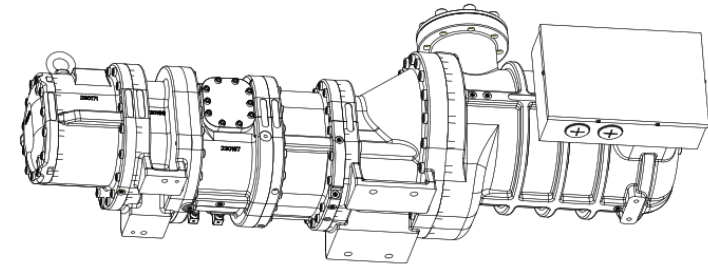
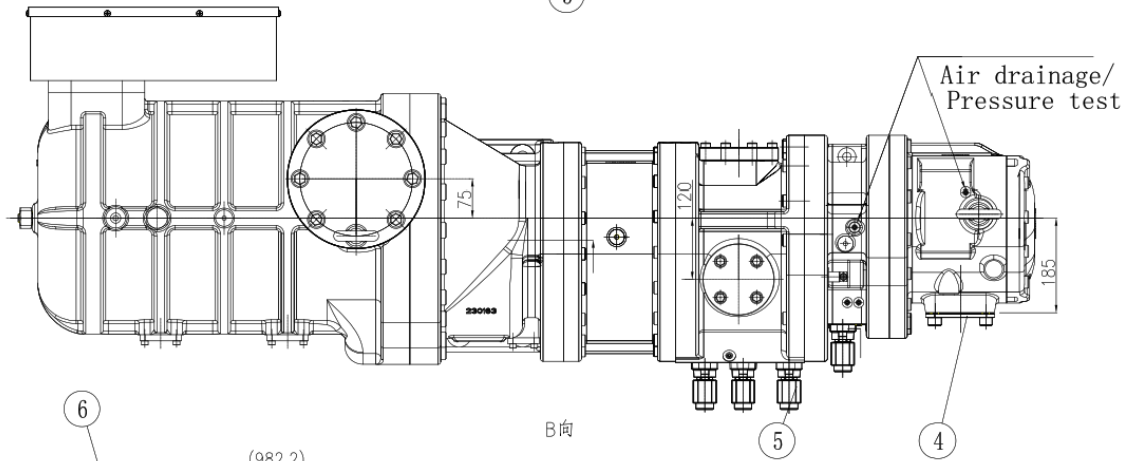
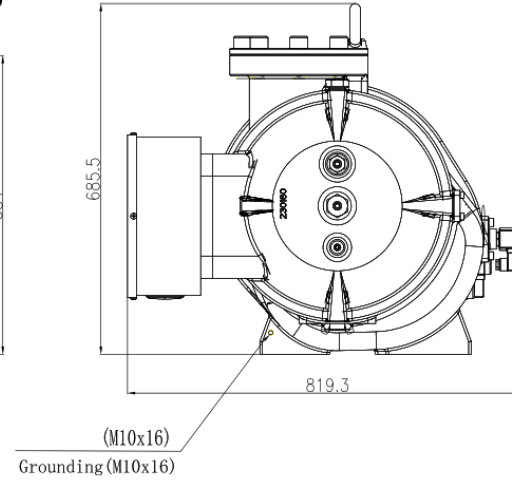
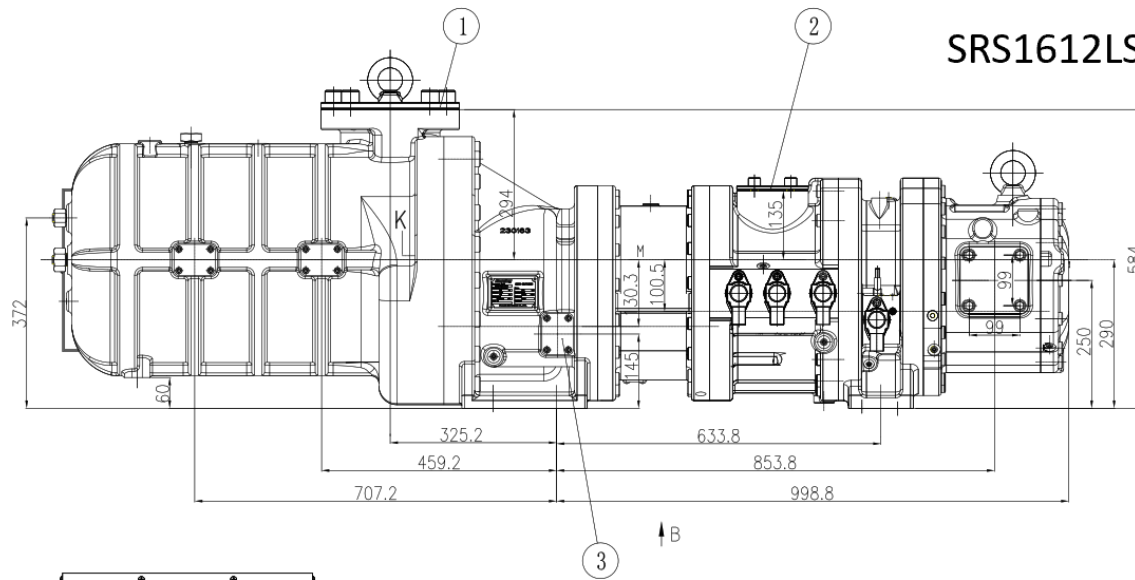

## KEY:

- 1、Single flap check valve/  
Lift check valve(Optional)  
(DN125 PN40)
- 2、ECO inlet port (DN32 PN40)
- 3、Oil inlet connection (DN32 PN40)
- 4、Discharge port (Ø60 PN40)
- 5、Solenoid valve
- 6、Oil Drainage (NPT 1/4")