

# CHECK VALVE

## CONTENTS

<b>SPECIFICATIONS .....</b>	<b>45</b>
<b>CHECK VALVES COMPONENTS .....</b>	<b>46</b>
<b>CHECK VALVES FROM 10 TO 250 mm FOR WELDING, S CLASS.....</b>	<b>47</b>
<b>CHECK VALVES FROM 10 TO 250 mm FOR WELDING, M CLASS .....</b>	<b>48</b>
<b>CHECK VALVES FROM 10 TO 100 mm FOR BRAZING, B CLASS .....</b>	<b>49</b>
<b>CHECK VALVES FROM 10 TO 32 mm FOR SOCKET WELDING, K CLASS.....</b>	<b>50</b>
<b>CHECK VALVES FROM 10 TO 250 mm FOR WELDING, H CLASS .....</b>	<b>51</b>



# CHECK VALVES

RFF Check valves may be supplied with a material certificate for the body and the bonnet which guarantees impact strength at  $-50^{\circ}\text{C}$ .

The nominal pressure rating is 25 bar, with possible higher pressure on request PN 40 or PN 65 (depending on diameter)

Check valves sizes 10 to 40mm and 125 to 250mm are sealed by PTFE, and check valves sizes 50 to 100mm are sealed by an O-ring.

To avoid damage during disassembly, check valves with PTFE seats (DN 10 to 40) have a captive seat assembly.

The size of a check valve on an installation should be carefully selected especially if ammoniac is used : The check valve should not be oversized or it may start to "chatter" when operating.

Branch connections on RFF check valves can be :

- # for butt welding, "S" class (standard series)
- # for butt welding, "M" class (Din 2448)
- # for brazing, "B" class
- # for socket welding, "K" class. (angle weld instead of full penetration weld).
- # for butt welding, "H" class Thickness 2mm for stainless steel pipe.

Check valves are supplied painted in blue to indicate the no-return function. Contrary to filters, they don't have a groove on the top surface of the flange.

Check valves can be installed in any position but it is recommended to use angle check valves vertically allowing the seats weight to aid closing.

### Spring strength for check valves :

<u>DN</u>	<u>START OPENING PRESSURE</u> (bar)	<u>END OPENING FORCE</u> (DaN)	<u>SEAT AREA</u> (cm <sup>2</sup> )
10/15	0.097	0.33	2.54
20/25	0.06	0.53	6.16
32/40	0.02	0.44	15.9
50	0.035	1.47	23.76
65	0.024	1.4	38.48
80	0.018	2	55.42
100	0.018	3.2	84.95
125	0.037	6.5	134.78
150	0.037	11	188.69
200	0.035	16.35	277.59
250	0.035	25	422.73

## CHECK VALVES

REFERENCES				
D	...	CR	x	x
Steel range	DN	Check valve	D : Straight E : Angle	<u>Connections</u> S : Butt welding ends – standard series M : Butt weldings end – Din 2448 B : Brazing ends K : Socket welding ends H : Butt welding Thickness 2 mm for stainless steel pipe

DN	BRANCH					BODY*	BONNET*	DISC-SEAL	BODY GASKET
10	S	M	H	B	K	TStE355	TStE355	PTFE on steel	O-ring
15	S	M	H	B	K	TStE355	TStE355	PTFE on steel	O-ring
20	S	M	H	B	K	TStE355	TStE355	PTFE on steel	O-ring
25	S	M	H	B	K	TStE355	TStE355	PTFE on steel	O-ring
32	S	M	H	B	K	TStE355	TStE355	PTFE on steel	O-ring
40	S	M	H	B	-	TStE355	TStE355	PTFE on steel	O-ring
50	S	M	H	B	-	TStE355	TStE355	O-ring on steel	Flat gasket
65	S	M	H	B	-	TStE355	TStE355	O-ring on steel	Flat gasket
80	S	M	H	B	-	GS21Mn5	TStE355	O-ring on steel	Flat gasket
100	S	M	H	B	-	GS21Mn5	TStE355	O-ring on steel	Flat gasket
125	S	M	H	-	-	GS21Mn5	P275NL2	PTFE on steel	O-ring
150	S	M	H	-	-	GS21Mn5	P275NL2	PTFE on steel	O-ring
200	S	M	H	-	-	GS21Mn5	P275NL2	PTFE on steel	O-ring
250	s	M	H	-	-	GS21Mn5	P275NL2	PTFE on steel	O-ring

# CHECK VALVES FROM 10 TO 250mm FOR WELDING "S"

STEEL

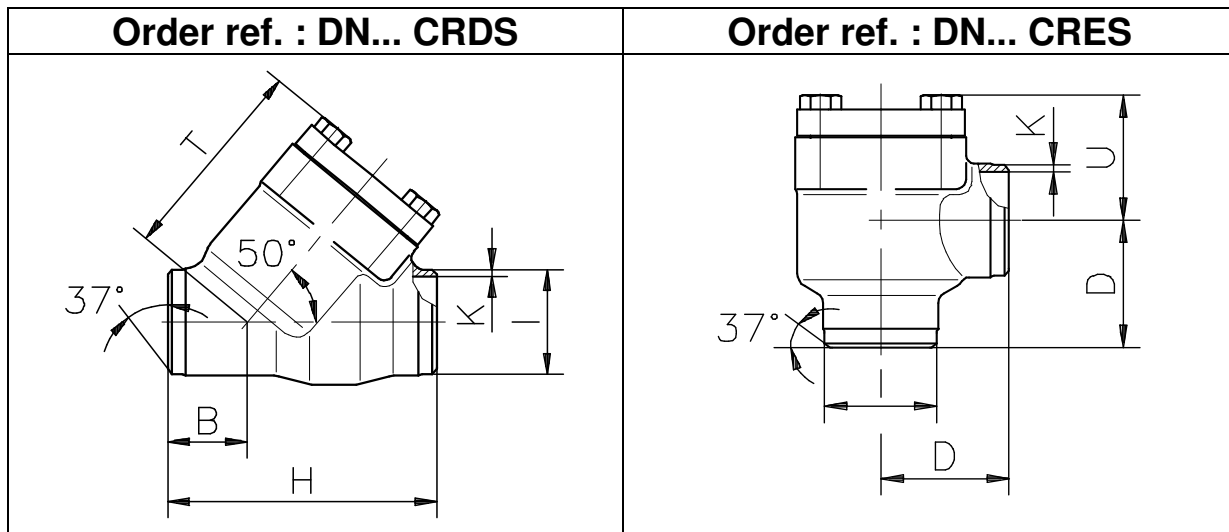

DIMENSIONS IN MILLIMETERS								
	DN	B	D	H	I	K	T	U
3/8"	10	25	39	85	17.2	2.3	55.6	39
1/2"	15	25	39	85	21.3	2.6	55.6	39
3/4"	20	33	46	110	26.9	2.9	71.5	46
1"	25	33	46	110	33.7	3.6	71.5	46
1 1/4"	32	40	57	130	42.4	3.6	93.5	55
1 1/2"	40	40	57	130	48.3	3.6	93.5	55
2"	50	41	69	152	60.3	4	118	68
2 1/2"	65 #	49	85	186	76.1	5	144	81
3"	80	54	85	238	88.9	5.6	177	89
4"	100	58	105	275	114.4	6.3	210	108
5"	125	66	120	308	141.3	7.1	258	135
6"	150	71	135	344	168.3	7.1	294	152
8"	200	88	170	427	219.1	8	370	188
10"	250	106	215	527	273	9.3	498	215

# DN 65 : Ref S065CRDUSA or S065CREUSA  
I = 73 , K = 5.2

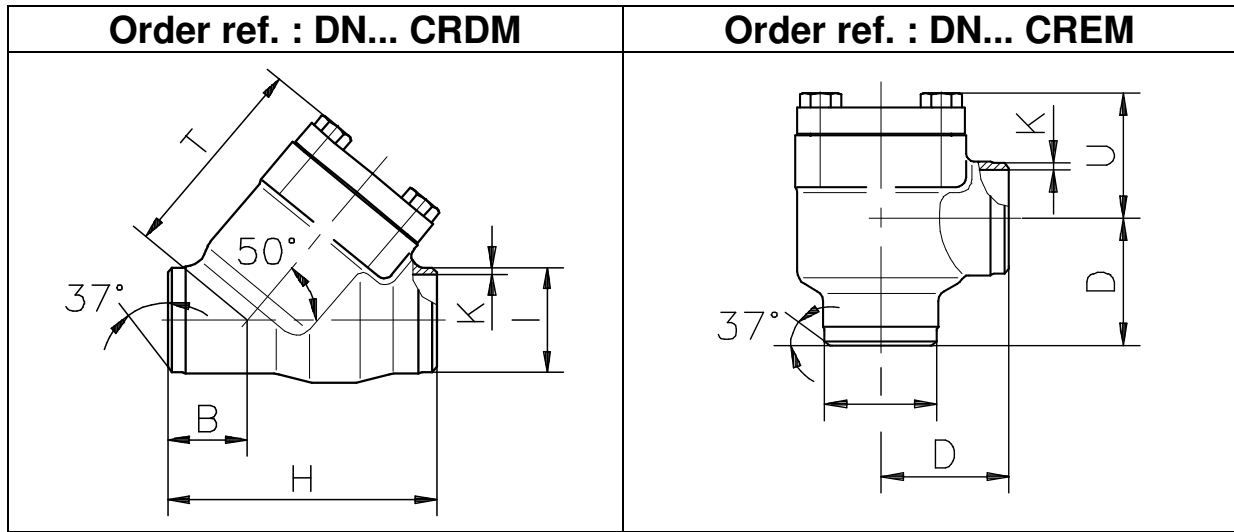

DIMENSIONS IN MILLIMETERS								
	DN	B	D	H	I	K	T	U
3/8"	10	25	39	85	17.2	1.8	55.6	39
1/2"	15	25	39	85	21.3	2	55.6	39
3/4"	20	33	46	110	26.9	2.3	71.5	46
1"	25	33	46	110	33.7	2.6	71.5	46
1 1/4"	32	40	57	130	42.4	2.6	93.5	55
1 1/2"	40	40	57	130	48.3	2.6	93.5	55
2"	50	41	69	152	60.3	2.9	118	68
2 1/2"	65	49	85	186	76.1	2.9	144	81
3"	80	54	85	238	88.9	3.2	177	89
4"	100	58	105	275	114.4	3.6	210	108
5"	125	66	120	308	141.3	4.5	258	135
6"	150	71	135	344	168.3	4.5	294	152
8"	200	88	170	427	219.1	6.3	370	188
10"	250	106	215	527	273	6.3	498	215

# CHECK VALVES FROM 10 TO 100mm FOR BRAZING "B"

STEEL

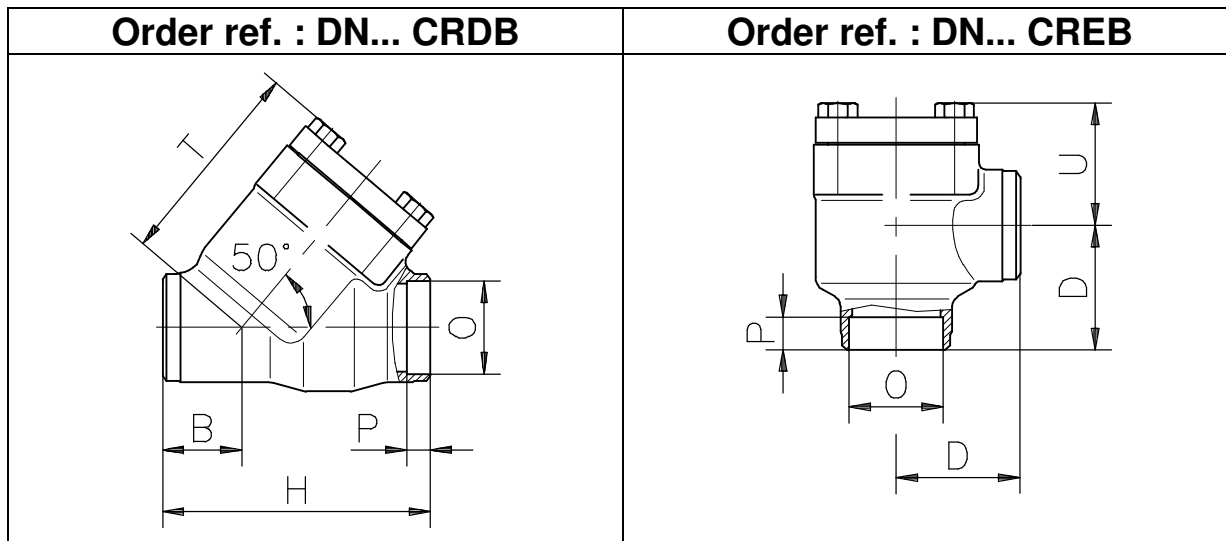

DIMENSIONS IN MILLIMETERS								
	DN	B	D	H	O	P	T	U
1/2"	10	25	39	85	12.9	12	55.6	39
5/8"	15	25	39	85	16.1	15.5	55.6	39
7/8"	20	33	46	110	22.4	20	71.5	46
1 1/8"	25	33	46	110	28.8	20	71.5	46
1 3/8"	32	40	57	130	35.2	22	93.5	55
1 5/8"	40	40	57	130	41.5	22	93.5	55
2 1/8"	50	41	69	152	54.2	25	118	68
2 5/8"	65	49	85	186	66.9	25	144	81
3 1/8"	80	54	85	238	79.6	30	177	89
4 1/8"	100	58	105	275	105	30	210	108

**CHECK VALVES FROM 10 TO 32 mm SOCKET "K"**

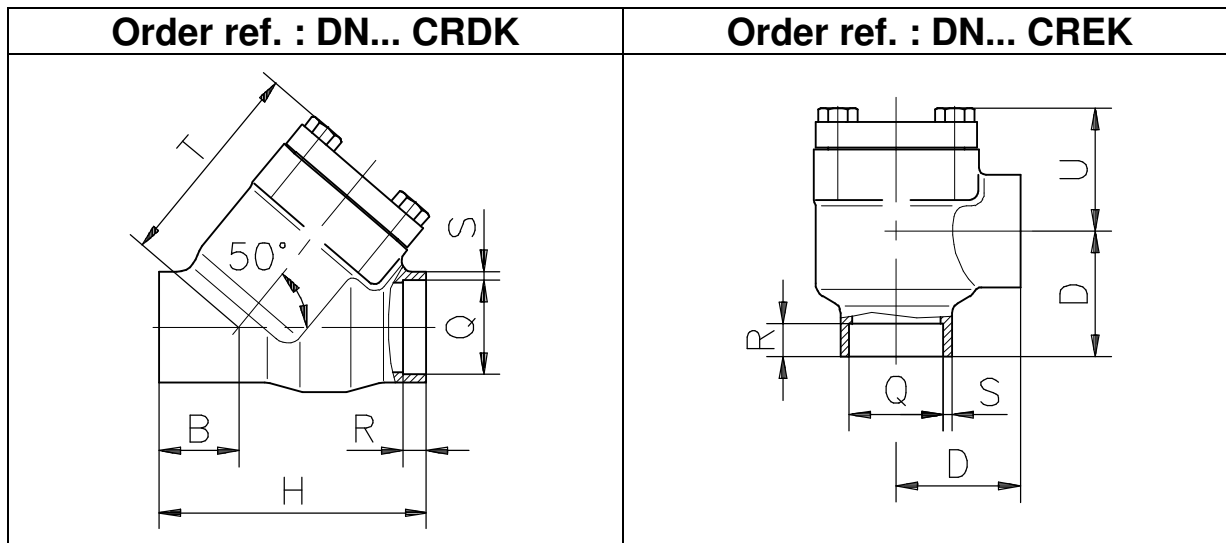

DIMENSIONS IN MILLIMETERS									
	DN	B	D	H	Q	R	S	T	U
3/8"	10	25	39	85	17.6	10	7.2	55.6	39
1/2"	15	25	39	85	21.9	10	5.1	55.6	39
3/4"	20	33	46	110	27.4	13	9.3	71.5	46
1"	25	33	46	110	34.1	13	5.9	71.5	46
1 1/4"	32	40	57	130	42.9	13	5.3	93.5	55



# CHECK VALVES FROM 10 TO 250mm FOR WELDING "H"

STEEL

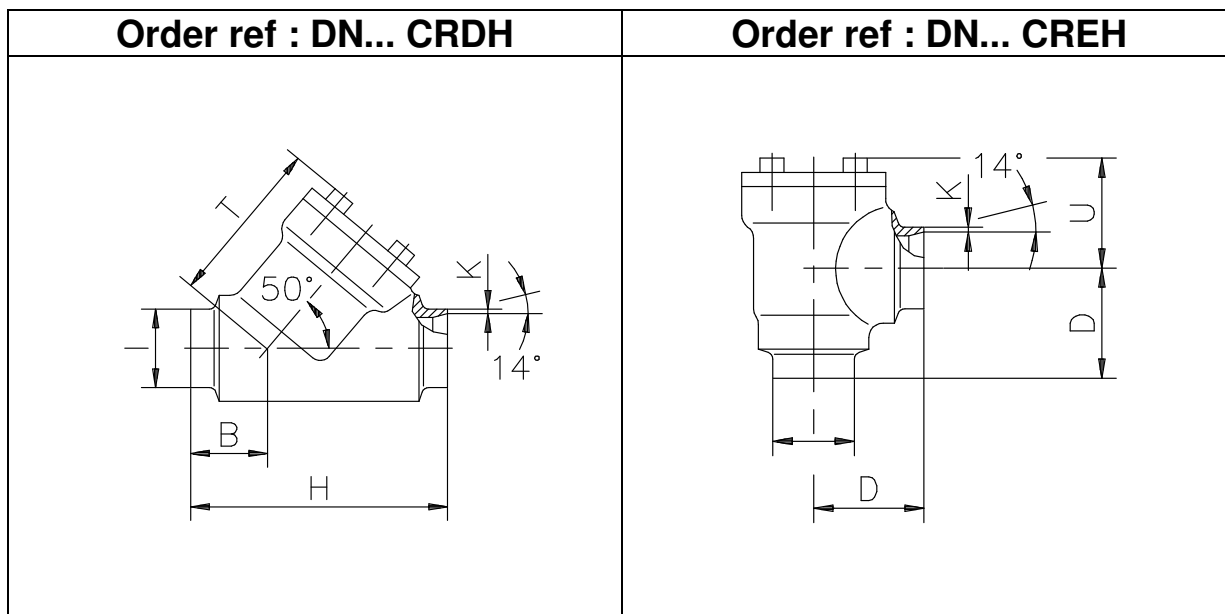

DIMENSIONS IN MILLIMETERS								
	DN	B	D	H	I	K	T	U
3/8"	10	25	39	85	17.2	2	55.6	39
1/2"	15	25	39	85	21.3	2	55.6	39
3/4"	20	33	46	110	26.9	2	71.5	46
1"	25	33	46	110	33.7	2	71.5	46
1 1/4"	32	40	57	130	42.4	2	93.5	55
1 1/2"	40	40	57	130	48.3	2	93.5	55
2"	50	41	69	152	60.3	2	118	68
2 1/2"	65	49	85	186	76.1	2	144	81
3"	80	54	85	238	88.9	2	177	89
4"	100	58	105	275	114.4	2	210	108
5"	125	66	120	308	141.3	2	258	135
6"	150	71	135	344	168.3	2	294	152
8"	200	88	170	427	219.1	2	370	188
10"	250	106	215	527	273	2	498	215



# STAINLESS STEEL CHECK VALVE FROM 10 TO 25 mm

STAINLESS

RFF check valves are constructed of Stainless steel shell CrNi 18-10 (1.4301) EN 10088-3. Internal parts are similar than standard steel valves.

RFF Check valves may be supplied with a material certificate for the body and the bonnet which guarantees impact strength at  $-50^{\circ}\text{C}$

Check valves sizes 10 to 25mm are sealed by PTFE.

The nominal pressure rating is 25 bar with temperature range from  $-50^{\circ}\text{C}$  up to  $+150^{\circ}\text{C}$ . Valves with higher pressure PN 65 is available on request with temperature range from  $-50^{\circ}\text{C}$  up to  $+110^{\circ}\text{C}$ .

To avoid damage during dismantling, check valves with PTFE seats (DN 10 to 25) have a captive seat assembly.

The size of a check valve on an installation should be carefully selected especially if ammoniac is used : The check valve should not be oversized or it may start to "chatter" when operating.

Branch connections on RFF check valves can be :

# for butt welding, "H" class  
(Thickness 2mm for stainless steel pipe)

Contrary to filters, Check valves do not have a groove on the top surface of the flange.

Check valves can be installed in any position but it is recommended to use angle check valves vertically allowing the seats weight to aid closing.

## Spring strength for check valves :

<u>DN</u>	<u>START OPENING PRESSURE</u> (bar)	<u>END OPENING FORCE</u> (DaN)	<u>SEAT AREA</u> ( $\text{cm}^2$ )
10/15	0.097	0.33	2.54
20/25	0.06	0.53	6.16

REFERENCES				
I	...	CR	x	x
Stainless steel range	DN	Check valve	D : Straight E : Angle	<u>Connections</u> H : Butt welding Thickness 2 mm for stainless steel pipe

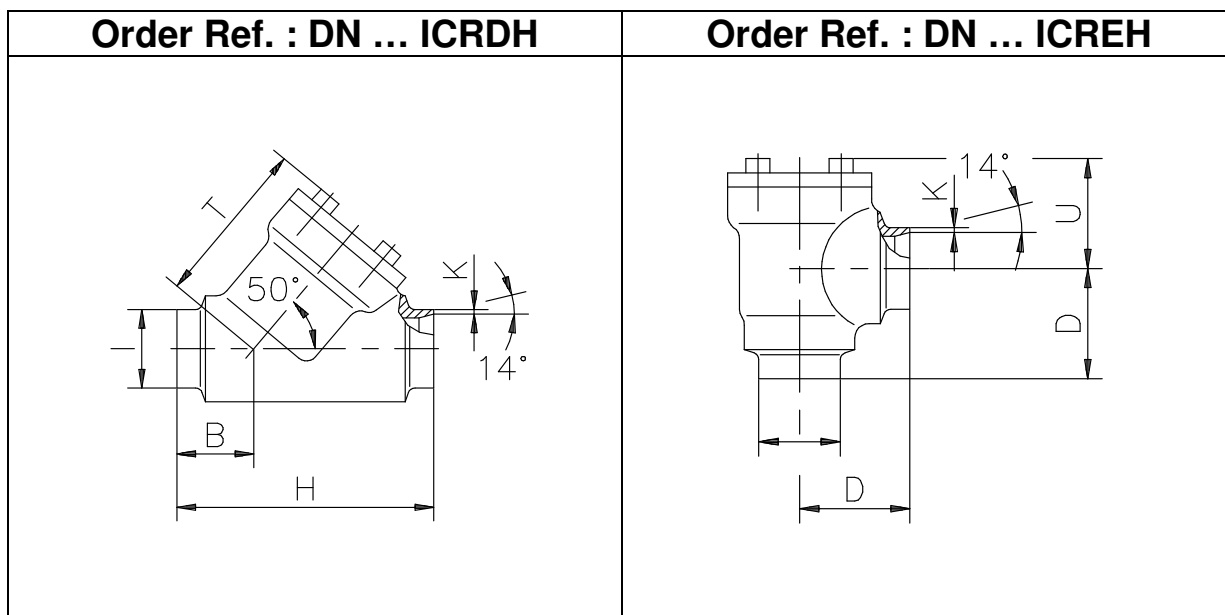

DIMENSIONS IN MILLIMETERS								
	DN	B	D	H	I	K	T	U
3/8"	10	25	39	85	17.2	2	55.6	39
1/2"	15	25	39	85	21.3	2	55.6	39
3/4"	20	33	46	110	26.9	2	71.5	46
1"	25	33	46	110	33.7	2	71.5	46